

LED Switching Power Supply

- Protections: short circuit/over load/over voltage/over temperature
- Soothing start, soft light and eye protection, with three gears dimming mode
- Intelligent recognition of LED strip working voltage
- Design for indoor installations
- Cooling by free air convection
- 100% full load burn-in test
- Widely used in LED lighting
- Compliance to worldwide safety regulation for led lightings.

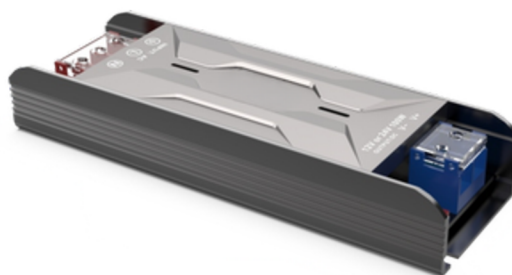

RoHS



SELV

IP20



Specification

Model		LAS-100WHCZ-12&24		LAS-100WHCZ-24&48	
OUTPUT	Output voltage	12VDC or 24VDC		24VDC or 48VDC	
	Output voltage range	12VDC±0.5VDC	24VDC±0.5VDC	24VDC±0.5VDC	48VDC±0.5VDC
	Output current	Max 8.5A	Max 4.2A	Max 4.2A	Max 2.08A
	Output power	Max 100W			
	Output power range	0~100W			
	Ripple & Noise	≤150mV	≤200mV	≤200mV	≤300mV
	Linear Regulation	±1%			
	Load Regulation	±1%			
	Start-up Time (Typ)	600ms/230VAC			
	Hold Up Time(Typ)	12ms/230VAC			
INPUT	Input voltage	175-264Vac			
	Frequency	50Hz			
	Input current	0.88A/230Vac or			
	Power factor	PF>0.55			
	No-load power consumption	<0.5W			
	Efficiency (typ.)	87%	88%	89%	90%
	Inrush current(typ.)	Cold start 60A at 230Vac			
	Control surge capability	L,N:1KV L,N-PE:2KV			
	Leakage current	Max. 0.5mA			
ENVIRONMENT	Working temperature	ta: -30°C~ 50°C tc: 80°C			
	Working humidity	20 ~ 99%RH, non-condensing			
	Storage temp., humidity	-40°C ~ 80°C, 10~95%RH			
PROTECTION	Overtemperature	With the increase of temperature, the output power gradually decreases until the output is turned off, and it will automatically recover after the temperature decreases.			
	Over load protection	Load current ≥110%~150%, turn off the output, the indicator flashes to remind, and it can be automatically restored after the fault is eliminated			
	Short circuit protection	The indicator flashes to remind, and it can be automatically restored after the fault is eliminated			
SAFETY & EMC	Withstand voltage	I/P-O/P:2000Vac			
	Isolation resistance	I/P-O/P: 100MΩ/500VDC/25°C/70%RH			
	Safety standards	IEC/EN61347;IEC/EN60950;IP20			
	EMC Test Standards	EN55015:2013;EN61547:2009; EN61000-3-2:2014; EN61000-3-3:2013			
Reliability and Quality Control	Impact aging	100% of the product is fully loaded and impacted for 4 hours under an environment of at least 40°C±5°C			
	Component derating	Under the steady-state conditions of rated input and output, the stress of components will not exceed its maximum nominal value			
NOTE	1. All parameters not specifically mentioned are measured at 230VAC input, rated load and 25°C ambient temperature. 2. Ripple and noise test method: connect 0.1uF and 47uF capacitors in parallel at the terminal, and measure under 20MHZ bandwidth. 3. Ensure that the power supply is used under the rated parameters and environment.				

Dimensions

Unit:mm

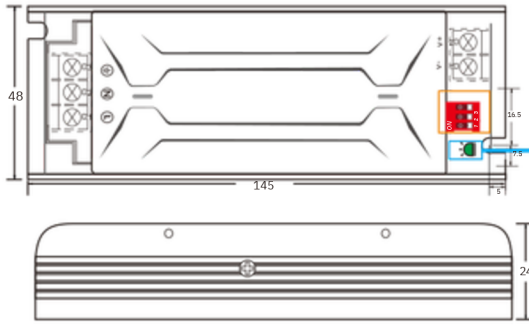

12V 24V

LAS-60WHCZ-12&24

- * Automatically identify different voltage strips and output the corresponding voltage;
- * When replacing the light strip, disconnect the power AC connection for longer than 2 seconds to avoid damaging the light strip.
- * When no active strip is recognized, the output voltage will be fixed at 12Vdc.

24V 48V

LAS-60WHCZ-24&48

- * Automatically identify different voltage strips and output the corresponding voltage;
- * When replacing the light strip, disconnect the power AC connection for longer than 2 seconds to avoid damaging the light strip.
- * When no active strip is recognized, the output voltage will be fixed at 24Vdc.



100% brightness output, no dimming



Three-stage dimming, 100% → 50% → 15% cycle, switch to the next stage brightness after each off on within 2 seconds, or remember the last brightness if off time longer than 2 seconds.



Five-stage dimming, 100% → 75% → 50% → 25% → 5% cycle. Turn off then turn on during 2 seconds, switch to the next stage brightness, or back to the last brightness if off time longer than 2 seconds.



Three-stage dimming, 100% → 50% → 15% cycle. Turn off then turn on during 2 seconds, switch to the next stage brightness, or back to the last brightness if off time longer than 2 seconds.



Slow start mode,

* In any case, turn on and off 3 times in 1 second reset to 100% brightness

Relationship diagrams

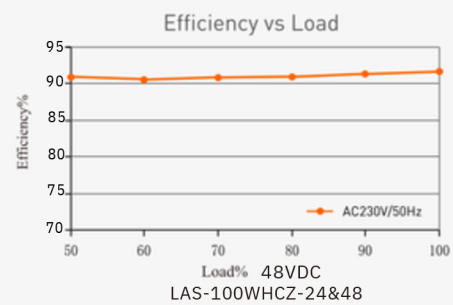
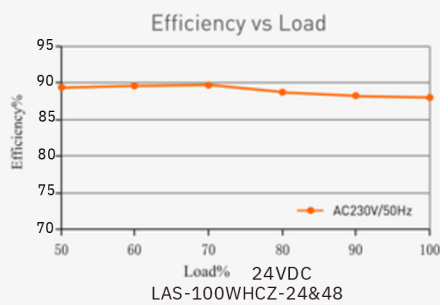
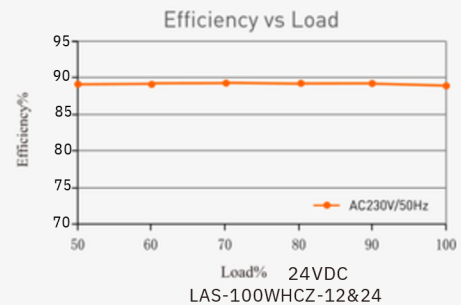
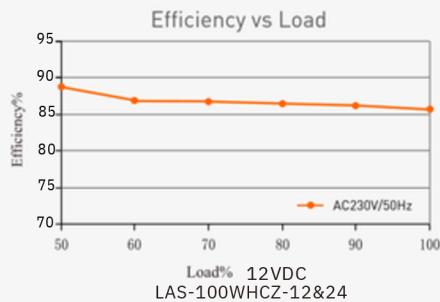

Packaging Information

DIMENSION	145x48x24mm(LxWxH)
PACKING	147x51x25mm(LxWxH)
CARTON QUANTITY	90PCS
CARTON SIZE	415x305x170mm(LxWxH)
WEIGHT	210g±10g/PCS

Temperature load curve

