

Constant Current & Dimmable Driver

Model: CC15WXXXTriac

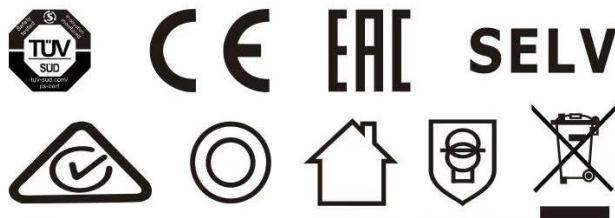

Model	Output Current	Input Current	Input Power	Output Power Range	PF	Efficiency	Output Voltage	No load Voltage
CC15W300 Triac	300mA	≤0.12A	≤20W	10.8-15W	≥0.92	≥80%	36-50V	≤65V
CC15W350 Triac	350mA	≤0.12A	≤20W	9.45-14.7W	≥0.92	≥80%	27-42V	≤55V
CC15W400 Triac	400mA	≤0.12A	≤20W	10.8-15.6W	≥0.92	≥80%	27-39V	≤55V
CC15W450 Triac	450mA	≤0.12A	≤20W	8.55-13.5W	≥0.92	≥80%	19-30V	≤45V
CC15W500 Triac	500mA	≤0.12A	≤20W	9.5-15W	≥0.92	≥80%	19-30V	≤45V
CC15W550 Triac	550mA	≤0.12A	≤20W	10.45-15.4W	≥0.92	≥80%	19-28V	≤45V
CC15W600 Triac	600mA	≤0.12A	≤20W	7.8-12.6W	≥0.92	≥80%	13-21V	≤35V
CC15W650 Triac	650mA	≤0.12A	≤20W	8.45-13.6W	≥0.92	≥80%	13-21V	≤35V
CC15W700 Triac	700mA	≤0.12A	≤20W	9.1-14.7W	≥0.92	≥80%	13-21V	≤35V

* Test result @230V, 50Hz, Full Load.

1. Parameters

Category	Item	Technical Norm
Features	Output Type	Constant Current
	Dimming Type	Phase dimming
	Dimming Range	10%-100%
	IP Grade	IP20
	Insulation Class	Class II
Input	Rated Input Voltage	220-240VAC_stable
	Range of Input Voltage	198-264VAC_stable or 180-280VDC_stable
	Frequency	50/60Hz
	Input Current	≤0.12A
	Input Power	≤ 20W
	Power Factor	≥0.92 (230VAC,full load)
Output	Current Accuracy	±5%
	Max. Output Power	15.6W
	Started Delay Time	≤0.5S (230VAC,full load)
	Current Ripple(< 120 Hz)	±5% (Imax-Imin) / (Imax+Imin)

	PstLM	≤1
	SVM	≤0.4
Protection	Short Circuit Protection	Auto Recovery
	Overload Protection	Auto Recovery
	No-load Protection	Auto Recovery
	Insulation voltage	I/P to O/P , 3.0KVac/5mA/1min
	Insulation resistance	>100M ohm @ 500VDC
	Leakage current	I/P to O/P < 250μA
Environment	Ta/Operation Temperature	-20....+50℃
	Ts/Storage Temperature	-40....+85℃
	Tc/Enclosure Temperature	85℃
	Humidity	10%....90%RH
	Atmosphere	86-108KPa
Construction	Connection Method	Direct Lead
	Installation	Built-in
	PRI Wire preparation	0.5-1.5 ^φ
	SEC Wire preparation	0.5-1.5 ^φ
	Dimension	68.2*36*23mm (L*W*H)
Standards	Certification	TUV、CE、SAA
	Safety Standards	EN61347-1:2015,EN61347-2-13:2014/A1:2017, EN62493:2015,AS/NZS IEC61347.2.13:2018, AS/NZS61347.1:2016 Inc AI
	EMC Standards	EN IEC 55015:2019,EN IEC 55015:2019/A11:2019, EN IEC 61000-3-2:2019, EN 61000-3-3:2013/A1:2019,EN61547:2009
	Performance	EN62384
	Surge	L-N/ 1KV
	Others	RoHS
	Life Time	50000h @Ta / Tc
	Warranty	5years , F.R. < 10000ppm
	Noise	≤28dB@Background noise ≤18dB , Interval≥15cm
Remark 1. All Parameters, if not specified, are measured at 230VAC/50Hz and 25℃ ambient temperature. 2. LED Driver is a component of the luminaires. Luminaires and wire layout will affect the EMC, please check the EMC with end products again.		

2. Trailing Edge Dimmer list approved by KGP

Manufacturer	Model	Q'ty of parallel connection
ABB	6519 U	12
ABB	6526 U	11
JUNG	1224 LED UDE	12
Berker	2861	12
JUNG	254 UDIE 1	13
JUNG	225 TDE	12
EGANT	U321V2	12
Schneider	SBD200LED	13
Schneider	SBD315RC	12
Merten	SBD200LED	13
Berker	2874	12
Eltako	EUD61NPL-230V	10
Eltako	EUD12NPN-UC	10
Eltako	EUD12D-UC	10
Eltako	EUD61NP-230V	10
Eltako	DTD55L-230V-wg	10
GIRA	Universal-LED-Dimmer Mini2440 00	10
EHMANN	LED-Dimmer T46.08	9
JUNG	Drehdimmer Universal LED1731DD	10
EHMANN	LED-Dimmer T46.03	10

Leading Edge Dimmer list only on request -/ or confirmed by KGP Electronics

3. Label

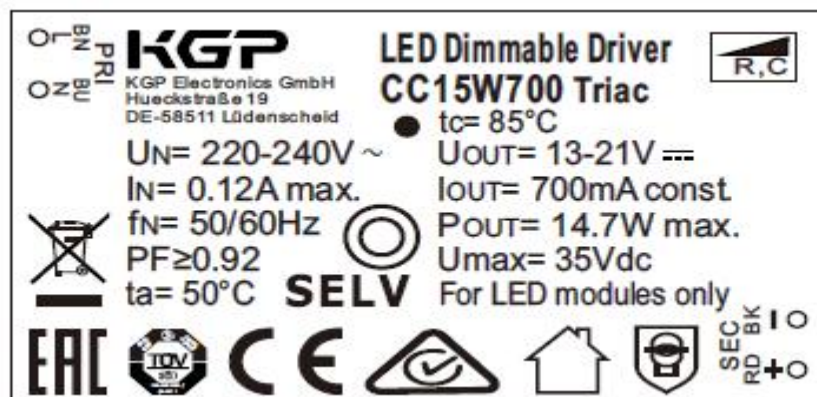

4. Connected quantities of different current Breaker

TYPE	Connected quantities of different current Breaker					Input Voltage	Inrush Current	Time
	current (A)	10	13	16	20			
	Installation wire diameter	1.5mm ²	2.5mm ²	2.5mm ²	4mm ²	4mm ²		
TYPE B		50	65	80	100	125	@230VAC	12
TYPE C		80	104	128	160	200		
TYPE D		128	166	205	256	320		

5. Dimming curve

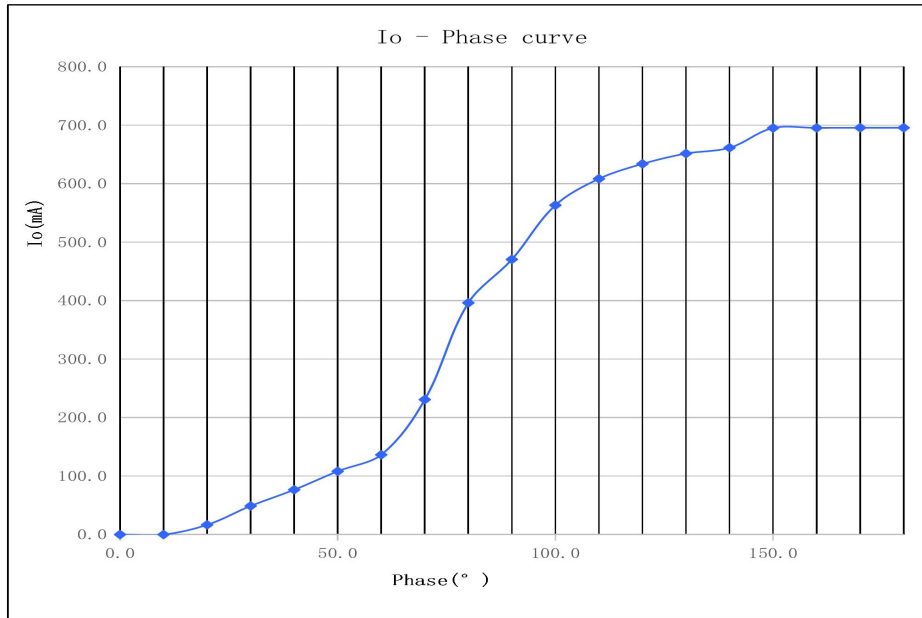

6. Lifetime curve

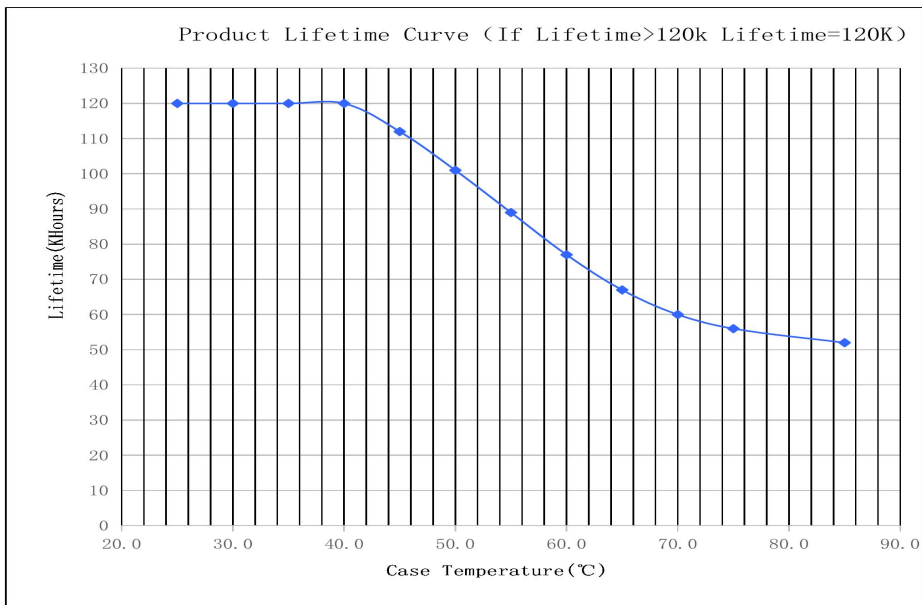

7. Dimension (Unit: mm)

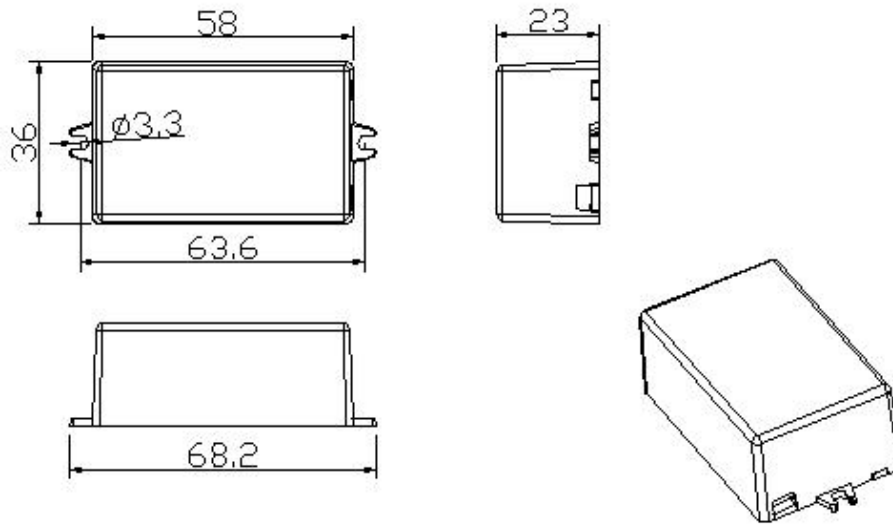

8. Wiring Diagram

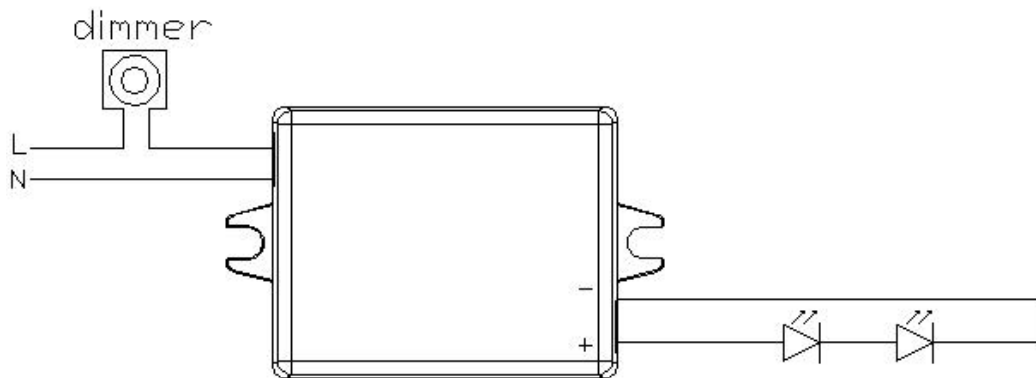

9. Packing information

Packing way	Model	Carton L*W*H(mm)	Pcs/ Carton	Net weight/ Pcs(kg)	Net weight/ Carton(kg)	Gross weight/ Carton(kg)
With white box and manual	CC15WXXX Triac	457*250*220	150	0.08	12	12.8
Without white box and manual		420*280*180	180	0.08	14.4	15.2

10. Wiring instructions

- All connections must be kept as short as possible to ensure good EMI behaviour
- Mains leads should be kept apart from LED Driver and other leads (ideally 5 – 10 cm distance)
- Advice the maximum length of output wires is 3 m
- Secondary switching is not permitted (Except for constant voltage)
- Incorrect wiring can damage LED modules.
- The wiring must be protected against short circuits to earth (sharp edged metals parts, metal cable clips, louver, etc.)