



**Constant Voltage & Dimmable Driver**

**Model: CV50W24CG Triac**



Model	Item Code	Output current range	Input Current	Output Power Range	PF	Efficiency	Output Voltage	No load Watt
CV50W24CG Triac	130361	0.5-2.08A	0.31A	12-50W	0.95	86%	24V	<1W

**\* Test result @230V, 50Hz, Full Load.**

**1.Parameters**

Category	Item	Technical Norm
Features	Output Type	Constant Voltage
	Dimming Type	Phase dimming
	Dimming Range	10%-100%
	IP Grade	IP20
	Insulation Class	Class II
Input	Rated Input Voltage	220-240VAC
	Range of Input Voltage	198-264VAC
	Frequency	50/60Hz
	Input Current	≤0.31A (198VAC , full load)
	Input Power	≤58W (230VAC , full load)
	Power Factor	≥0.95 (230VAC , full load)
	THD	≤20% (230VAC , full load)
	No-load Power Consumption	≤1W @230VAC
	Inrush Current	5A&500us(Cold start)
	Connected quantity of 16A Breaker :	16pcs/type B ; 26pcs/type C @ 230Vac
Output	Output Voltage	24V
	Output Current	500-2080mA
	Max. Output Power	50W
	Efficiency	≥86% (230VAC , full load)
	Ripple & Noise (Max)	900mVp-p
	Current Accuracy	±5%
	Started Delay Time	≤0.5S (230VAC , full load)
Protection	Short Circuit Protection	Auto Recovery
	Overload Protection	Auto Recovery
	No-load Protection	Auto Recovery
	Ta/Operation Temperature	-25....+50°C

Environment	Ts/Storage Temperature	-20....+70°C
	Tc/Enclosure Temperature	70 °C
	Humidity	5%....85%RH
	Atmosphere	86-108KPa
	Connection Method	Captured Terminal screw
Construction	Installation	Independent
	PRI Wire preparation	0.75-2.5mm <sup>2</sup>
	SEC Wire preparation	0.75-2.5mm <sup>2</sup>
	Dimension	Independent:184x61x32mm (L*W*H)
	Certification	complied to CE
Standards	Safety Standards	EN61347-1:2015,EN61347-2-13:2014/A1:2017 ,EN62493:2015
	EMC Standards	EN55015:2013/A1:2015,EN61000-3-2:2014,E N61000-3-3:2013,EN61547:2009
	Surge	L-N/1KV
	RoHS	complied to 2011/65/EU
Others	Life Time	50000h @Ta / Tc
	Warranty	5years , F.R. < 10000ppm

Remark: 1. Specific instructions are not all parameters are not connect dimmer input voltage 230 vac / 50 Hz and 25 °C ambient temperature measured.

2. LED Driver is a component of the luminaires, Luminaires and wire layout will affect the EMC, please check the EMC with end products again.

3. Trailing edge dimmable.

## 2. Trailing Edge Dimmer list approved by KGP

Dimmer	Trade mark	Load type	Ratings	
C-Bus L5504D2U	Clipsal	L,C	220-240V 50-60Hz	Universal
D350S	AcTEC	R,L	220-240V~50/60Hz 10-350W/VA	Trailing
Cat 400T	HPM		230-240Vac 50Hz 10-400W	Trailing
32E450T	Clipsal		220-240V a.c. 50Hz 10-450W	Trailing
315GLE	ELKO		230VAC 50Hz 40-315W	Trailing
6513U-102	Busch(ENST0)	R,C	230V 50Hz 420W/VA	Trailing
SBD315RC	Schneider	R,C	230V~ 50Hz 20-315VA	Trailing
MCU Te250	OSRAM		AC220-240V 50Hz 20-250W	Trailing
AB300	OmniTronix		230/240V 50Hz 10-300W	Trailing

**Leading Edge Dimmer list only on request -/ or confirmed by KGP Electronics**

### 3.Label



### 4.Packing information

Carton L*W*H(mm)	Pcs/Carton	Net weight/ Pcs(kg)	Net weight/ Carton(kg)	Gross weight / Carton(kg)
385*335*195	50	0.240	12.0	13.4

### 5.Ordering data

Model No	Item code
CV50W24CG Triac	130361

### 6.Dimension (Unit: mm)

L x W x H : 184x61x32

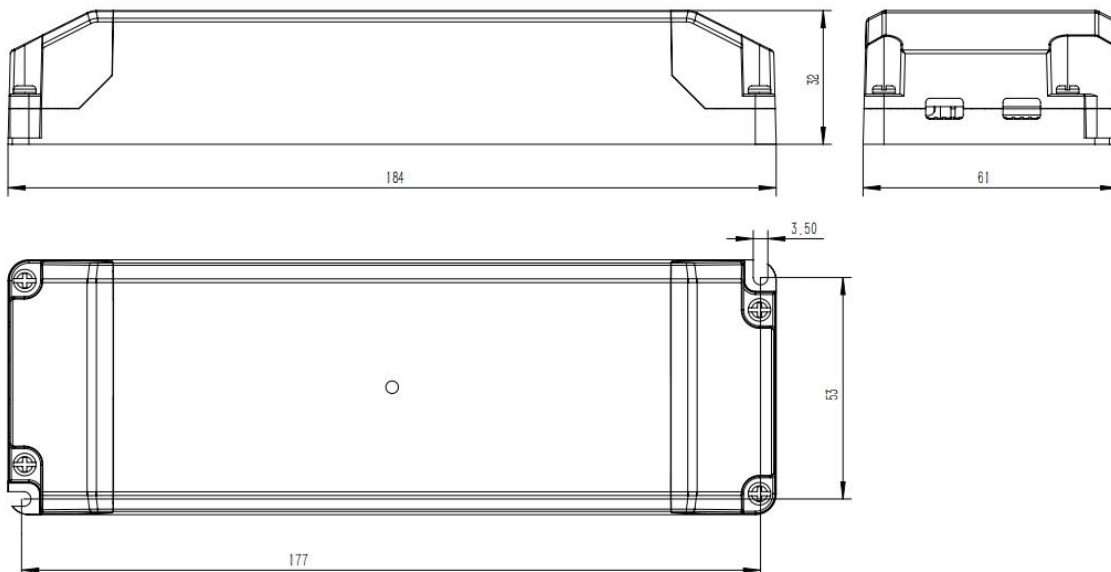

## 7.Wiring Diagram

Push Wire connection : 0.75-2.5mm<sup>2</sup>

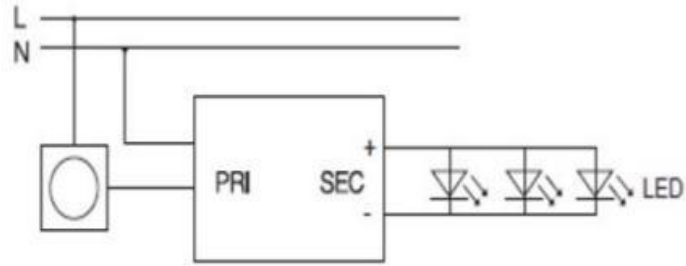

## 8.Revision history

Date	Version	Remark
2023-06-27	V1.0	Initial release.
2024-10-29	V2.0	Font & format adjustment
2025-08-04	V3.0	Add item code